



C5002000P Ultrasonic Line Voltage Ceiling Mount Sensor

Installation and Operation Instructions

DESCRIPTION

C5002000 Class 2, 24V AC Ultrasonic ceiling mount sensor. Supplied with mounting plate and mounting screws. To be used with G.E. RR7 Remote Switching Relay.

FEATURES

1. 200 sq. ft. area of coverage.
2. Adjustable time delay 30 seconds to 30 minutes
3. Adjustable sensitivity

PRE-INSTALLATION

1. For installation by a qualified electrician in accordance with national and local codes and the following instructions.
2. For indoor use only
3. CAUTION: RISK OF ELECTRIC SHOCK. Disconnect power before installing. Never wire energized electrical components.
4. CAUTION: USE COPPER CONDUCTOR ONLY
5. Check to see that the device type and rating are suitable for the application.
6. If moisture or condensation is evident, allow the product to dry completely before installation.
7. Do not install if any damage to the product is noticed

Mounting – Unit should be mounted using a single gang plaster ring attached to an approved box.

INSTALLATION

1. WARNING: Check that power is turned off at circuit breaker before installing the sensor.
2. Connect and mount the sensor as outlined in the drawing on reverse side. Use approved wire nuts for all electrical connections.
3. Attach the sensor to the ceiling by mounting it to a 4” square mud ring with the supplied mounting plate.
4. Energize the sensor and allow it to warm up (approximately 3 minutes).
5. Set the time delay and sensitivity (see ADJUSTMENT INFORMATION below) and check operation with a walk test. The lights should turn of and the LED should also blink when detection motion.

ADJUSTMENT INFORMATION

Adjustments for time delay and sensitivity along with the bypass slot are located on the end of the device.

Time Delay

The adjustment for the time delay is labeled in “MINUTES”. The minimum setting of 30 seconds (0.5) is fully counterclockwise while the maximum setting of 30 minutes is clockwise. This setting dictates the duration of time the device will keep the lights on after no motion has been detected.

Sensitivity

The minimum sensitivity adjustment is fully counterclockwise while the maximum sensitivity is fully clockwise. In general, the larger the room, the higher the sensitivity should be set.

Bypass (override)

The sensor can be bypassed to keep the lights on if required. This should be done for emergency or testing purposes only. To override the sensor to stay on, insert the bypass key (provided) into the slot labeled “Bypass”.

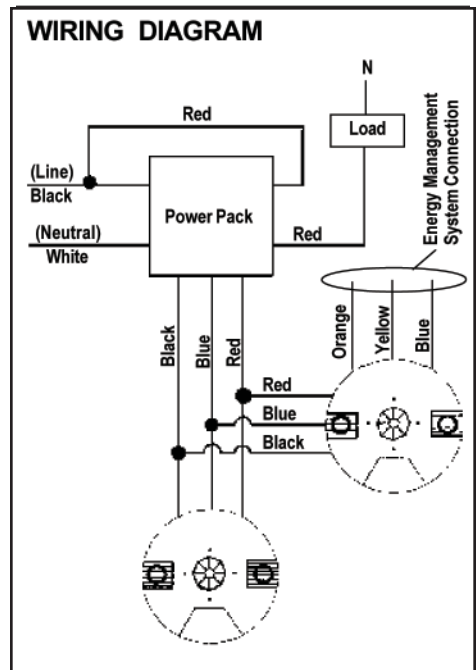
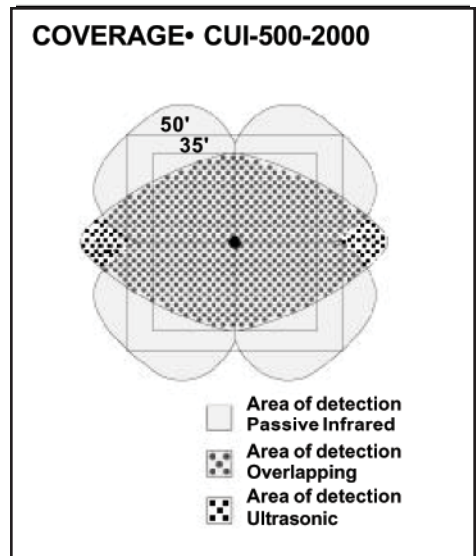
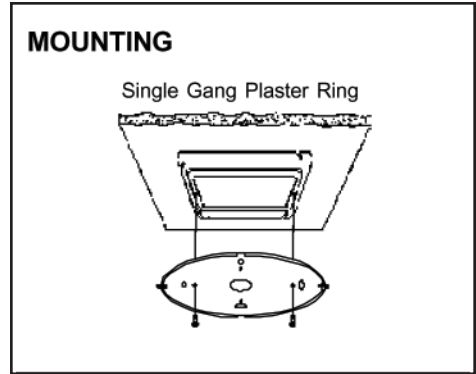

***Switch Position**

Switches 1-5 control ultrasonic and passive infrared settings

Switches 6-7 are for selecting proper room size.

After setting the adjustments for room size, choose the program below that best fits the description of the area being controlled.

Room Size Selection

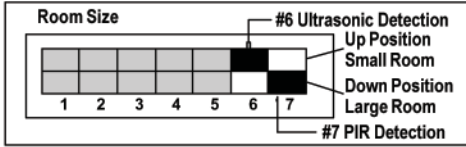

Program selections for #6 & #7 are selection of either large or small room as listed below:

#6 Ultrasonic detection

UP = Small room (400 sq. ft. or less)

DOWN = Large room (up to 2000 sq. ft.)

#7 Passive Infrared detection

UP = Small room (400 sq. ft. or less)

DOWN = Large room (up to 2000 sq. ft.)

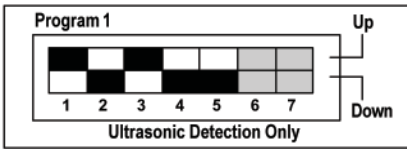

#1 Program Selection

Used in common office areas. Using this program will enhance the detection that is needed in partitioned office areas. This program only uses ultrasonic detection.

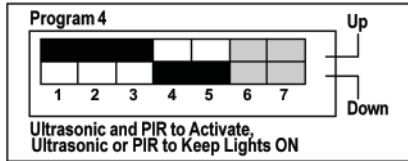

#4 Program Selections

Used in rooms and areas such as in classrooms that require minor motion detection, but cannot be falsely triggered by turbulence (hanging mobiles, etc.). Sensitivity increases after lights are switched on.

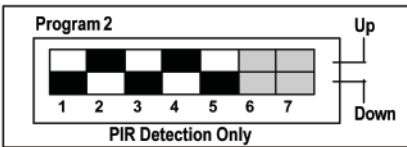

#2 Program Selections

Used in areas which turbulence such as air draft or high air flow from ceiling registers in a problem. This program only uses passive infrared detection. If environmental conditions are too severe for this program selection, use program selection #5

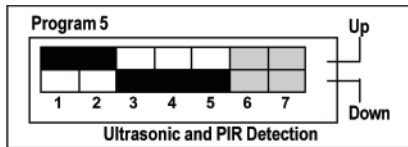

#5 Program Selections

Used in areas where turbulent conditions exist in which no other program selection can satisfy. This selection requires both ultrasonic and passive infrared detection to simultaneously occur in order to trigger the timing circuit that will ultimately keep the lights on.

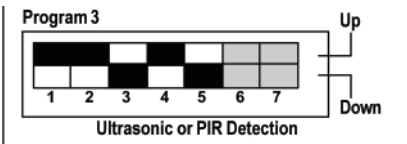

#3 Program Selections

Used in areas in which high sensitivity is needed and no turbulence or adverse environmental conditions exist. This program selection permits maximum sensitivity by using both ultrasonic and passive infrared technology.

