



Wall Switch Occupancy Sensors

LightHawk™ Passive Infrared Dual Circuit Wall Switch Sensor featuring IntelliDAPT®

KEY FEATURES

- All-digital passive infrared (PIR) sensor
- IntelliDAPT self-adaptive technology—no manual adjustment required
- 2 relays for either two-level switching or dual-circuit control
- Auto-on and manual-on operating modes (depending on model)
- 1,000 square-foot, 180° coverage area
- Built-in photocell with SuperSaver™ mode
- RhinoTuff™ lens
- Dual 120/277 VAC operation
- No minimum load requirement
- Zero Arc Point Switching
- ETL, UL, and cUL listed
- 5-year warranty



LHIRD2

LHIRD0

OVERVIEW

LHIRD sensors use passive infrared (PIR) technology for unequaled occupancy detection and false trip immunity, providing improved accuracy. The sensors, designed for dual-level lighting applications, possess 2 primary circuits (each with independent switching).

LHIRD sensors feature Hubbell Building Automation’s patented IntelliDAPT technology, which makes all the sensor adjustment decisions automatically. Throughout the product’s lifespan, smart software analyzes the controlled area and makes digital adjustments to sensitivity and timer settings. Occupancy sensors with IntelliDAPT provide a maintenance-free “Install and Forget” operation. With selectable operating modes—automatic ON/OFF or manual ON/automatic OFF—and a built-in photosensor for automatic daylight harvesting, LHIRD sensors are the best choice in today’s market place.

FEATURES and BENEFITS

Features

IntelliDAPT technology

All-digital passive infrared (PIR) sensor

2 relays for either two-level switching or dual-load control

Auto-on and manual-on operating modes (depending on model)

Tamper-proof automatic-only version available

RhinoTuff lens

Built-in photocell with optional SuperSaver mode

Benefits

- Sensor automatically determines the ideal setting for an area
- No manual sensitivity or timer adjustments required
- Provides a maintenance-free “Install and Forget” operation
- Excellent long-range major-motion detection
- Controls 2 circuits (120 VAC and/or 277 VAC) independently
- Provides auto-on/auto-off and manual-on/auto-off operations
- Automatically turns lighting on and off without requiring you to push a button
- Impact-resistant infrared (IR) lens
- Increases energy savings by preventing lights from turning on when there is sufficient natural light
- Optional SuperSaver mode—turns lights off during periods of occupancy if there is enough natural light to illuminate the area

SPECIFICATIONS

IntelliDAPT technology	<ul style="list-style-type: none"> • Self-adjusting timer • Self-adjusting passive infrared (PIR) sensitivity • Automatic false-on/false-off corrections • No manual adjustments required
Timer timeout	<ul style="list-style-type: none"> • Auto mode: 4–30 minutes; self-adjusts based on occupancy • Fixed mode: 4, 8, 15, and 30 minutes • Test mode: 5 seconds
Passive infrared (PIR)	<ul style="list-style-type: none"> • Dual-element pyrometer and 12-element cylindrical RhinoTuff lens
Photocell	<ul style="list-style-type: none"> • Natural light override range: 10–500 foot-candles
Coverage	<ul style="list-style-type: none"> • 1,000 square-foot, 180° coverage area
Power requirements	<ul style="list-style-type: none"> • 120/277 VAC; 50/60Hz
Electrical ratings	<ul style="list-style-type: none"> • 120VAC: 800W Incandescent; 1,000W Fluorescent; 1/6 HP • 277VAC: 1,800W Fluorescent; 1/6 HP
Load requirements	<ul style="list-style-type: none"> • None
Operating environment	<ul style="list-style-type: none"> • Indoor use only • Operating temperature: 32°–104° F (0°–40° C) • Relative humidity (non-condensing): 0%–95%
Construction	<ul style="list-style-type: none"> • Casing—high-impact injection-molded plastic (UL-94-5V) • Impact-resistant lens • Color-coded leads are 6" long
Size and weight	<ul style="list-style-type: none"> • Size: 4.2" x 1.8" x 2.1"; .37" extension • Weight: 2.9 oz
Color	<ul style="list-style-type: none"> • White; Ivory; Light Almond; Gray; Black
Mounting	<ul style="list-style-type: none"> • Single-gang NEMA-style switch box (average switch box) • Decorator-style wall plate not included
Certifications	<ul style="list-style-type: none"> • ETL, UL, and cUL listed

HOW TO ORDER

Catalog Number	Description
LHIRD2*	Passive Infrared Dual Circuit Wall Switch Sensor with IntelliDAPT and Automatic/Manual Control, 120/277VAC
LHIRD0*	Passive Infrared Dual Circuit Wall Switch Sensor with IntelliDAPT and Automatic Only Control, 120/277VAC

* = W – White, I – Ivory, A – Light Almond, G – Gray, B – Black

RANGE DIAGRAM

*Refer to Application Guide.

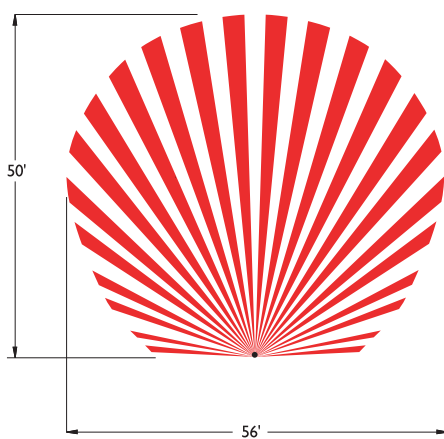

■ IR Motion

WIRING DIAGRAM

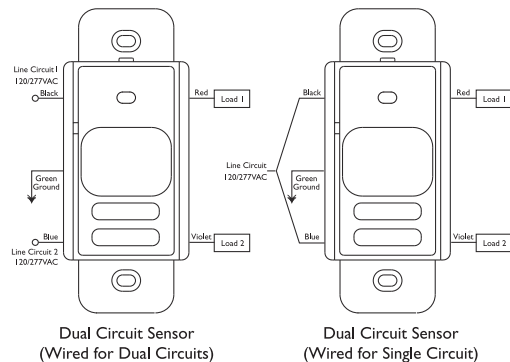

Building Automation, Inc.

Hubbell Building Automation, Inc.
 9601 Dessau Road | Building One | Austin, Texas 78754
 {512} 450-1100 | {512} 450-1215 fax
hubbell-automation.com